



MOUNTING NUTS

Stud Nut

Part Number	Across Flats	Nut Thickness	Nut (Thread)
<u>N12-16</u>	1 3/32"	27/64"	3/4-16

Rod Nut

Part Number	Across Flats	Nut Thickness	Nut (Thread)
<u>N06-24A</u>	9/16"	7/32"	3/8-24
<u>N06-24B</u>	1/2"	3/32"	3/8-24

CB-2095

Clevis Bracket
Material: Steel, bright zinc plated

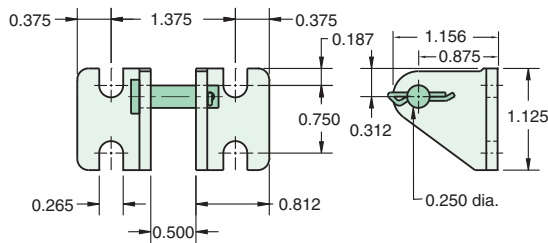

RC-2081

Rod Clevis
Material: Steel, electroless nickel plate

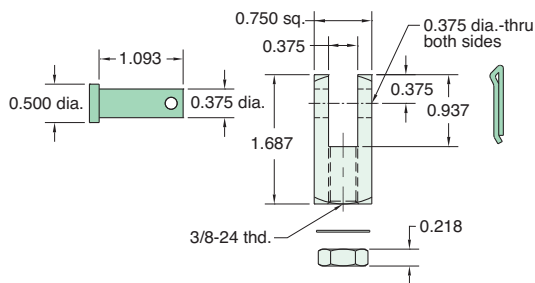

RE-2085

Rod End
Material: Steel, bright zinc plated body

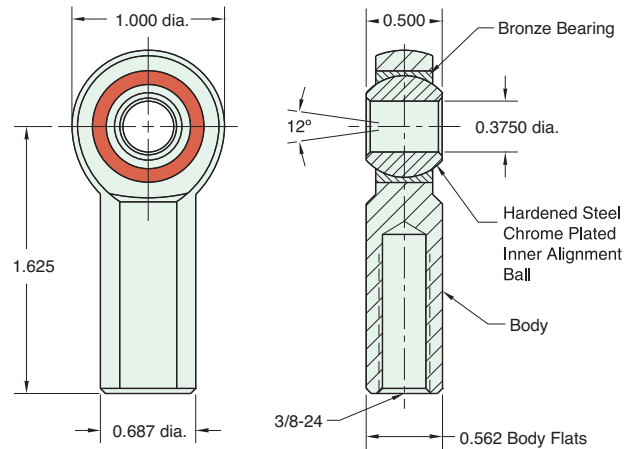

Lockwasher

Locknut

Max. Static Radial Load (rod end only): 3,950 lbs.
Fits Rod Thread Size: 3/8-24

FB-2491

Foot Bracket
Material: Steel, bright zinc plated

